

Mathematical coupling does not explain the relationship between right ventricular end-diastolic volume and cardiac output

Loren D. Nelson, MD, FACS, FCCM; Karen Safcsak, RN; Michael L. Cheatham, MD, FACS; Ernest F.J. Block, MD, FACS, FCCM

Objective: To evaluate the clinical significance of mathematical coupling on the correlation between cardiac output and right ventricular end-diastolic volume (RVEDV) through measurement of cardiac output by two independent techniques.

Design: Prospective, observational study.

Setting: Surgical intensive care unit in a level 1 trauma center.

Patients: Twenty-eight critically ill surgical patients who received mechanical ventilation and hemodynamic monitoring with a pulmonary artery catheter.

Interventions: A pulmonary artery catheter designed to measure right ventricular ejection fraction (RVEF) and cardiac output by the intermittent bolus thermodilution (TDCO) method and continuous cardiac output by the pulsed thermal energy technique was placed. A computerized data logger was used to collect data simultaneously from the RVEF/TDCO system and the continuous cardiac output system.

Measurements and Main Results: Two hundred forty-nine data sets from 28 patients were compared. There is statistical correlation between TDCO and continuous cardiac output measure-

ments ($r = 0.95$, $p < 0.0001$) with an acceptable bias (-0.11 L/min) and precision (± 0.74 L/min). The correlation was maintained over a wide range of cardiac outputs (2.3–17.8 L/min). There is a high degree of correlation between RVEDV and both TDCO ($r = 0.72$, $p < 0.0001$) and independently measured continuous cardiac output ($r = 0.68$, $p < 0.0001$). These correlation coefficients are not statistically different ($p = 0.15$).

Conclusions: The continuous cardiac output technique accurately approximates cardiac output measured by the TDCO method. RVEDV calculated from TDCO correlates well with both TDCO and independently measured continuous cardiac output. Because random measurement errors of the two techniques differ, mathematical coupling alone does not explain the correlation between RVEDV estimates of preload and cardiac output. (Crit Care Med 2001; 29:940–943)

KEY WORDS: cardiac output; preload; pulmonary artery occlusion pressure; central venous pressure; right ventricular ejection fraction; end-diastolic volume; mathematical coupling; critical illness; oxygen delivery; oxygen transport; monitoring

Augmentation of ventricular preload is a key component in the resuscitation of critically ill patients in shock. Starling's law of the heart defines preload as the cardiac myofibril length at end-diastole. The ventricular end-diastolic volume is proportional to this length and therefore can be used to estimate preload. However, until the mid-1990s, serial bedside measurements of end-diastolic volume were unavailable. Because of difficulty in assessing end-diastolic volume, clinicians often relied upon the assessment of right and left ventricular filling pressures as surrogate estimates of preload (1). The correlation between intracardiac filling pressures and end-diastolic volume is dependent upon ventricular compliance. Because ventricular compliance can

change drastically in critically ill patients and intracardiac filling pressures are significantly affected by changes in intra-abdominal and intrathoracic pressure, the intracardiac filling pressures (pulmonary artery occlusion pressure [PAOP] and central venous pressure) are poor predictors of fluid responsiveness during shock resuscitation (2–4).

The development and clinical introduction of the right ventricular ejection fraction (RVEF) pulmonary artery catheter provides a reliable method for measuring right ventricular end-diastolic volume (RVEDV) (1). Multiple studies demonstrate that measurements of RVEDV using the intermittent bolus thermodilution (TDCO) method correlate well with both cardiac output and responsiveness to fluid administration (2–4). However, some researchers question the clinical significance of the correlation between RVEDV and cardiac output (5), inasmuch as RVEDV is calculated using cardiac output and any correlation between these two derived variables may be

due to the presence of shared measurement error or "mathematical coupling."

The purpose of this investigation is to compare RVEDV with cardiac output measured by two independent techniques, thereby eliminating the effect of mathematical coupling on the correlation between RVEDV and cardiac output. Similar statistical correlations between RVEDV and cardiac output measured by the two techniques minimizes the clinical significance of mathematical coupling and increases the utility of RVEDV as a predictor of preload responsiveness during shock resuscitation.

MATERIALS AND METHODS

This prospective study was conducted in the 22-bed adult surgical intensive care unit of a regional level 1 trauma center. Twenty-eight consecutive patients who received a pulmonary artery catheter for evaluation of acute cardio-respiratory insufficiency were studied. Patients with atrial fibrillation, tachycardia > 150 beats/min, or other irregularities of cardiac rhythm that precluded measurement of

From the Department of Surgical Education, Orlando Regional Medical Center, Orlando, FL.

Sponsored, in part, by an unrestricted educational grant from Edwards Lifesciences, LLC, Irvine, CA.

Copyright © 2001 by Lippincott Williams & Wilkins

RVEF were excluded. The study protocol was reviewed and informed consent waived by the Orlando Regional Healthcare System Institutional Review Board for the Protection of Human Subjects.

All patients were mechanically ventilated with low-rate intermittent mandatory ventilation and pressure support ventilation titrated to patient comfort and a spontaneous ventilatory rate ≤ 30 breaths/min. Positive end-expiratory pressure (mean 14 ± 7.5 cm H₂O, range 5–35 cm H₂O) was titrated to keep arterial oxyhemoglobin saturation (SpO₂) ≥ 0.92 on FiO₂ ≤ 0.40 . Patients received aggressive resuscitation with blood product transfusions, crystalloid boluses, and, when needed, inotropes to maintain hemodynamic stability of blood pressure and adequate tissue perfusion as indicated by urine output and clearance of metabolic acidosis. The therapeutic goal of all interventions was to maximize oxygen delivery and restore adequate organ perfusion.

Each patient received a pulmonary artery catheter designed for the measurement of continuous cardiac output (CCO) by the pulsed thermal energy technique (Swan Ganz CCombo/EDV, 757HF8, Edwards Lifesciences, LLC, Irvine, CA). This catheter contains a rapid response thermistor that allows intermittent bolus thermodilution measurement of RVEF. Catheters were placed using standard insertion techniques and appropriate positioning was confirmed by a portable chest radiograph and a pulmonary artery occlusion waveform noted with inflation of the balloon to maximal volume (1.25–1.5 mL). The pulmonary artery catheter was connected to a bedside pressure monitor (Merlin, Hewlett Packard Medical, Andover, MA) and a commercially available cardiac output computer capable of thermodilution measurement of RVEF (Explorer, Edwards Lifesciences, LLC). All clinical assessments of the patient's hemodynamics and treatment decisions were based upon measured and derived data from these two commonly used monitoring devices.

For the purpose of the study, the pulmonary artery catheter was also connected to a second commercially available monitoring device (Vigilance, Edwards Lifesciences, LLC) capable of measuring CCO by the pulsed thermal technique (monitoring time 4–18 hrs). CCO data were obtained during periods of relative cardiopulmonary stability and hemodynamic support. Although the patients received continuous infusion of resuscitation fluids and vasoactive medications (13 patients received Levophed or Dopamine to maintain systolic blood pressure > 90 mm Hg) when indicated, fluid boluses and changes in vasoactive infusions or ventilatory support were not made during these measurements. After at least 20 mins of stable CCO measurements, the pulmonary artery catheter thermistor was recon-

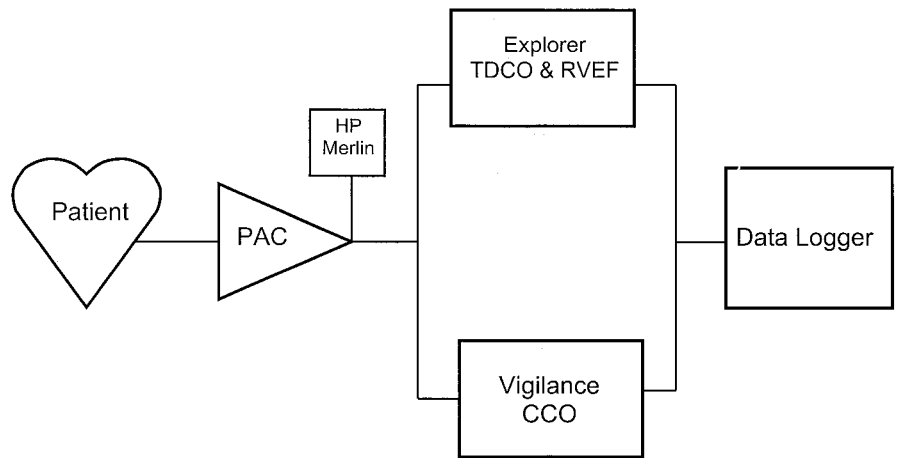

Figure 1. Data collection setup. The PAC thermistor is connected to the Explorer for TDCO/RVEF measurements. PAC, pulmonary artery catheter; HP, Hewlett Packard bedside pressure monitor; TDCO/RVEF, intermittent bolus thermodilution cardiac output and right ventricular ejection fraction; CCO, continuous cardiac output.

nected to the TDCO/RVEF monitor. A series of four or five cardiac output measurements was made using 10-mL injections of room temperature injectate (6). Injections were synchronized with end-expiration of mechanical ventilator breaths. The first value from each series and those that were technically inadequate (i.e., hand slipping off syringe piston, loose connections) were discarded. A single researcher (KS) performed all measurements to improve the consistency of the technique used. RVEF data obtained from the intermittent thermodilution cardiac output curves were used to calculate the RVEDV. All measurements and derived variables were recorded continuously using a computerized data logger specifically designed for use in this study (Fig. 1).

Mean values of paired data were compared using Student's *t*-test. Linear regression analysis was used to calculate the Pearson product moment correlation coefficient. Fisher's *z* transformation was used to compare correlation coefficients for statistical differences. The bias and precision of CCO vs. TDCO measurements were calculated using the method of Altman (7).

RESULTS

Two hundred forty-nine data sets were collected from 28 patients. Patients entered in the study were from the following surgical services: trauma ($n = 14$), general surgery ($n = 9$), and vascular surgery ($n = 5$). Patients' ages ranged from 19 to 85 yrs (mean 53 ± 18). There is no statistical difference between CCO and TDCO (7.7 ± 2.4 L/min vs. 7.8 ± 2.4 L/min, $p = 0.60$). The bias and precision for the mean value of both cardiac output

techniques is -0.11 and ± 0.74 L/min, respectively. There is a high degree of statistical correlation between CCO and TDCO ($r = 0.95$, $p < 0.0001$) over a wide range of cardiac outputs (2.3–17.8 L/min). There is a statistical correlation between thermodilution-determined RVEDV and both the TDCO ($r = 0.72$, $p < 0.0001$) (Fig. 2) and CCO ($r = 0.68$, $p < 0.0001$) (Fig. 3). There is no statistical difference between the correlation coefficients obtained by continuous vs. intermittent estimates of cardiac output and RVEDV calculated from the TDCO-derived stroke volume ($p = 0.15$).

DISCUSSION

The latest generation of pulmonary artery catheters determines the end-diastolic volume of the right ventricle by dividing stroke volume by the RVEF. Ejection fraction is determined using a rapid response thermistor, calculating the thermal residuals produced by beat-to-beat changes in temperature during the logarithmic portion of the thermal decay curve produced during thermodilution cardiac output measurement (8). The accuracy of thermodilution RVEF measurements has been confirmed by ventriculography (9–10), echocardiography (11), and radionuclide studies (12).

Because the RVEDV is calculated by dividing stroke volume by RVEF, cardiac output becomes a shared variable in the calculation of both stroke volume and RVEDV. Stroke volume is equal to cardiac output divided by heart rate, and RVEDV is equal to stroke volume divided by

TD Cardiac Output vs TD RVEDV

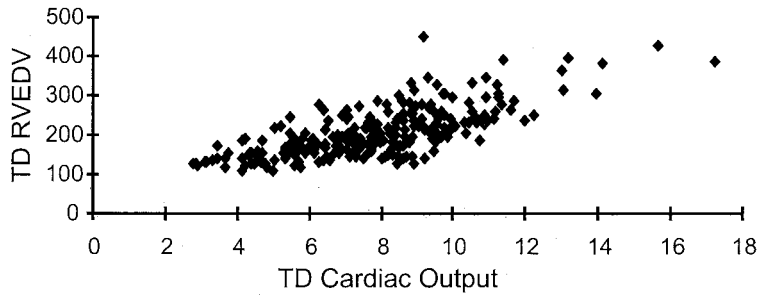

Figure 2. Relationship between intermittent bolus thermodilution (TD) measurement of cardiac output and right ventricular end-diastolic volume (RVEDV) derived from the same measurement of cardiac output ($r = 0.72, p < 0.0001$).

Continuous Cardiac Output vs TD RVEDV

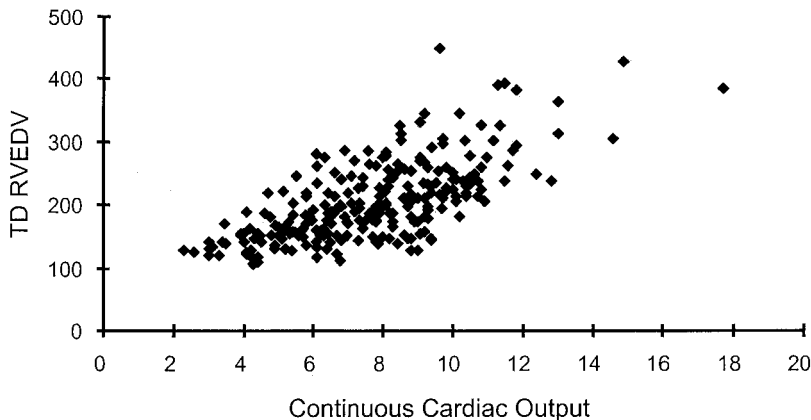

Figure 3. Relationship between continuous thermal pulse measurement of cardiac output and right ventricular end-diastolic volume (RVEDV) derived from the intermittent measurement of cardiac output by thermodilution (TD) ($r = 0.68, p < 0.0001$).

RVEF. Therefore, RVEDV is equal to cardiac output divided by heart rate divided by RVEF.

Sharing of a measured variable in calculation of derived variables creates a situation where statistical correlation between variables (mathematical coupling) is likely. The greater the error range of the shared variable, the greater is the impact of mathematical coupling.

Mathematical coupling, as a source of erroneous statistical correlation, was brought to the forefront of clinical literature by Archie (13) in 1981. He defined mathematical coupling as a statistical relationship between derived variables due to a common measured component. A frequently used example of mathematical coupling is the observed relationship between oxygen delivery and oxygen consumption, where both variables are calculated using a common cardiac output. Any variation in cardiac output, whether

real or erroneous, will result in a change in both oxygen delivery and oxygen consumption in the same direction as the change in cardiac output. Statistical tests designed to identify a correlation between the two derived variables can be positive as a result of their shared component. Civetta et al. (5) subsequently published an abstract suggesting that removal of shared variables between RVEDV and cardiac index eliminated the correlation between these two variables. The authors concluded that mathematical coupling alone explained the correlation between RVEDV and cardiac output.

Diebel and Wilson (2) in 1992 first demonstrated the significant correlation between RVEDV and cardiac output in a group of critically ill surgical patients who were being actively resuscitated with fluids. The authors demonstrated that patients with a low RVEDV were fluid responsive and their cardiac output in-

creased in response to a fluid challenge. The PAOP was not a significant predictor of what was termed "preload recruitable" increases in cardiac output. In a series of investigations beginning in 1993, we have demonstrated similar significant correlations between RVEDV and cardiac output in various groups of high-risk, critically ill surgical patients (14–18). These studies have consistently demonstrated a lack of correlation between PAOP and cardiac output. We have concluded from these investigations that the RVEDV is a superior predictor of fluid responsiveness compared with PAOP or central venous pressure.

Durham et al. (19) in 1995 confirmed the clinical utility of RVEDV as a measure of cardiac preload. The authors demonstrated a statistically significant relationship between RVEDV and cardiac index that remained significant even after correcting for the potential effect of mathematical coupling using the technique described by Stratton (20).

Chang et al. (21) in 1996 conducted a carefully designed prospective trial to investigate the relationship between both PAOP and RVEDV and cardiac output. The study demonstrated a relationship between RVEDV and cardiac output, but no statistical correlation between PAOP and cardiac output. Because of the concern for possible mathematical coupling, oxygen consumption was measured by an independent technique and cardiac output was calculated using the Fick equation. The authors found a significant correlation between Fick-derived cardiac output and cardiac output measured by TDCO. They also found a statistically significant correlation between RVEDV and both measurements of cardiac output. Furthermore, there was no difference in the statistical correlation between RVEDV and cardiac output measured by the two techniques. The authors concluded from this study that mathematical coupling was not a significant source for the correlation between RVEDV and cardiac output.

Similarly, in this study we have reconfirmed that mathematical coupling is not a significant cause for the correlation between RVEDV and cardiac output. There is a close relationship between cardiac output measured by the continuous technique and by the TDCO method. Furthermore, RVEDV calculated from the TDCO curve correlates well with cardiac output measured by either the TDCO or CCO methods. Because there are no shared

variables between these two independent monitoring techniques, mathematical coupling alone does not explain the statistical correlation between RVEDV and cardiac output.

Because the sources and magnitude of measurement error differ between the TDCO and CCO measurements, they are truly independent measurement techniques. The time constant for CCO measurements is several minutes, for TDCO is 10–30 secs, and for RVEF is several heartbeats. Physiologic variation as a source of error is dependent upon the time constant used. Random error of the measurements differs between the TDCO and CCO techniques. TDCO uses the area inscribed by the pulmonary artery blood temperature reduction curve after a bolus of injectate below body temperature. CCO uses an algorithm relating increases in blood temperature in response to pseudo-randomly generated pulses of thermal energy produced by a heating coil in the central circulation. The magnitude and direction of the blood temperature changes produced by the two techniques differs significantly.

It would seem that one of the limitations of this study is that the same thermistor is used to calculate cardiac output by both the continuous and the intermittent thermodilution methods. However, use of the same thermistor is advantageous in that it is more likely to produce consistent results in the calculation of temperature-derived variables. Even though the same thermistor is used for the two different thermodilution methods, random measurement errors are different between the two techniques. TDCO is significantly affected by the timing and consistency of the injection (22, 23). In this study, we chose to average data from a minimum of three injections that were made at end-expiration. This technique has been shown to produce a more consistent cardiac output value than randomly timed injections (24). Changes in pulmonary artery temperature that occur during the ventilatory cycle and true physiologic changes of right ventricular afterload and preload of both ventricles caused by fluctuating airway pressure are minimized by this injection method.

This is the third study showing a clinically insignificant contribution of mathematical coupling to the relationship between RVEDV and cardiac output in

critically ill patients. The effect of mathematical coupling was shown by Durham et al. (19) to be of no clinical importance when statistical techniques were used to eliminate the effect of shared variables on the calculated variables. The study by Chang et al. (21) demonstrated no clinically significant effect on the correlation between RVEDV and cardiac output when cardiac output was calculated independently using the Fick technique. Finally, this study shows no significant effect on the correlation between RVEDV and cardiac output when cardiac output is measured by the independent continuous thermodilution technique.

Mathematical coupling does not contribute in a clinically significant manner to the relationship between RVEDV and cardiac output and, therefore, does not negate the validity of RVEDV as a useful predictor of preload recruitable increases in cardiac output.

REFERENCES

1. Nelson LD: The new pulmonary artery catheters: Continuous venous oximetry, right ventricular ejection fraction, and continuous cardiac output. *New Horiz* 1997; 5:251–263
2. Diebel LN, Wilson RF, Tagett MG, et al: End-diastolic volume—A better indicator of preload in the critically ill. *Arch Surg* 1992; 127:817–821
3. Diebel LN, Wilson RF, Heins J, et al: End-diastolic volume versus pulmonary artery wedge pressure in evaluating cardiac preload in trauma patients. *J Trauma* 1994; 37: 950–955
4. Chang MC, Blinman TA, Rutherford EJ, et al: Preload assessment in trauma patients during large volume resuscitation. *Arch Surg* 1996; 131:728–731
5. Civetta JM, Kirton O, Hudson-Civetta J, et al: Mathematical coupling: Why correlations of right ventricular function are so good? Abstr. *Crit Care Med* 1995; 23:A126
6. Safcsak K, Nelson LD: Thermodilution right ventricular ejection fraction (RVEF) measurements: Room vs cold temperature injectate. *Crit Care Med* 1994; 22:1136–1141
7. Altman DG: Statistics and ethics in medical research. *BMJ* 1980; 281:1473–1475
8. Safcsak K, Nelson LD: Right heart volumetric monitoring: Measuring preload in the critically ill patient. *AACN Clin Issues* 1999; 10:22–31
9. Urban P, Scheidegger D, Gabathuler J, et al: Thermodilution determination of right ventricular volume and ejection fraction: A comparison with biplane angiography. *Crit Care Med* 1987; 15:652–655
10. Voelker W, Gruber H, Ickrath O, et al: Determination of right ventricular ejection fraction by thermodilution technique—A comparison to biplane cineventriculography. *Intensive Care Med* 1988; 14:461–466
11. Jardin F, Brun-Ney D, Hardy A, et al: Combined thermodilution and two-dimensional echocardiographic evaluation of right ventricular function during respiratory support with PEEP. *Chest* 1991; 99:162–168
12. Kay HR, Afshari M, Barash P, et al: Measurement of ejection fraction by thermal dilution techniques. *J Surg Res* 1983; 34:337–346
13. Archie JP: Mathematic coupling of data: A common source of error. *Ann Surg* 1981; 193:296–303
14. Chang MC, Cheatham ML, Safcsak K, et al: Differences in hemodynamic and oxygen transport variables produced by blood and crystalloid during volume resuscitation. Abstr. *Crit Care Med* 1994; 22:A107
15. Safcsak K, Nelson LD, Cheatham ML, et al: Pressure vs. volume predictions of ventricular preload in patients with pulmonary hypertension. Abstr. *Crit Care Med* 1994; 22: A102
16. Fusco MA, Safcsak K, Nelson LD: Volumetric assessment of preload in the septic patient. Abstr. *Chest* 1994; 106:64S
17. Cheatham ML, Nelson LD, Chang MC, et al: Right ventricular end-diastolic volume index as a predictor of preload status on positive end-expiratory pressure. *Crit Care Med* 1998; 26:1801–1806
18. Cheatham ML, Safcsak K, Block EFJ, et al: Preload assessment in the patient with an open abdomen. *J Trauma* 1999; 46:16–22
19. Durham R, Neunaber K, Vogler G, et al: Right ventricular end-diastolic volume as a measure of preload. *J Trauma* 1995; 39: 218–224
20. Stratton HH, Feustel PJ, Newell JC: Regression of calculated variables in the presence of shared measurement error. *J Appl Physiol* 1987; 62:2083–2093
21. Chang MC, Black CS, Meredith JW: Volumetric assessment of preload in trauma patients: Addressing the problem of mathematical coupling. *Shock* 1996; 6:326–329
22. Armengol J, Man GCW, Balsys AJ, et al: Effects of the respiratory cycle on cardiac output measurements: Reproducibility of data enhanced by timing the thermodilution injections in dogs. *Crit Care Med* 1981; 9:852–854
23. Jansen JRC, Versprille A: Improvement of cardiac output estimation by the thermodilution method during mechanical ventilation. *Intensive Care Med* 1986; 12:71–79
24. Snyder JV, Powner DJ: Effects of mechanical ventilation on the measurement of cardiac output by thermodilution. *Crit Care Med* 1982; 10:677–682